

Cylinder Pressure Sensor CPS-03CA

for On-line Combustion control

Cylinder pressure sensor for on-line combustion control on diesel- and gas engines for increasing engine performance and optimised engine control.

Characteristics

- Extreme robust against high dp/dt
- Designed life expectancy of 16,000 h
- Digital electronic with event storing
- Very good thermodynamic performance
- Protection class IP69

Application:

Closed loop control on internal combustion engines e.g. knock detection, cylinder balancing, MIP calculation, start of combustion, NOx control

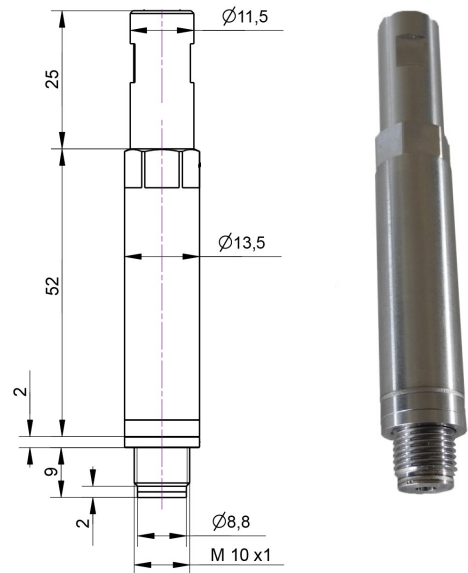

Technical data

Measuring range pressure	0...300 bar
Over pressure static	800 or 1200 bar
Frequency range	10 kHz
Thermal shock 1500 RPM pmi=10bar	< +/- 0,5 bar
Accuracy	≤1% Full scale
Max. temperature at measuring cell	300 °C (short time 1 min 350°C)
Temperature range of SCU	-40 °C ... + 75 °C
Supply voltage	18...32 VDC
SCU current consumption	≤50 mA (continuous operation); 250 mA (switch-on peak)
Output signal	4...20 mA
Sensitivity	53,33 µA/bar
Electrical connector	HTOE10-6P-F42-A34-SPL acc.to MIL-C-26482
Thread	M10 x 1,0
Dimension sensor	52 mm , Ø 13,5 mm
Dimension electronic	115 mm x 18 mm
Tightening torque	15 Nm
Weight incl. electronic	250 g

General specifications

Degree of protection	IP 69 (EN 60529)
CE approval	2004/1008/EG EN 61000-6-2 EN 61000-6-4 EN 61326-1
Marine qualification	
DNV-GL	TAA00000H0
Bureau Veritas	22261/C1BV
Class NK	TA20507M
Korean Register	HMB43238-AE001
American Bureau Of Shipping	20-2044594-PDA
Lloyd's Register	11-20041(E1)-03

Optimum sensor life is achieved at an average temperature at the measuring element of 200 - 250 °C.

The life expectancy of the sensor has been designed so that the lifetime of 16.000 h or more can be achieved in a gas engine. at 1500 rpm.

Mounting

The sensor should be installed close to the combustion chamber, the length of the pressure bore between sensor and combustion chamber depends mainly on engine speed.

Generally there are two possibilities for the installation position of cylinder pressure sensors:

Head mounted or set-back mounted.

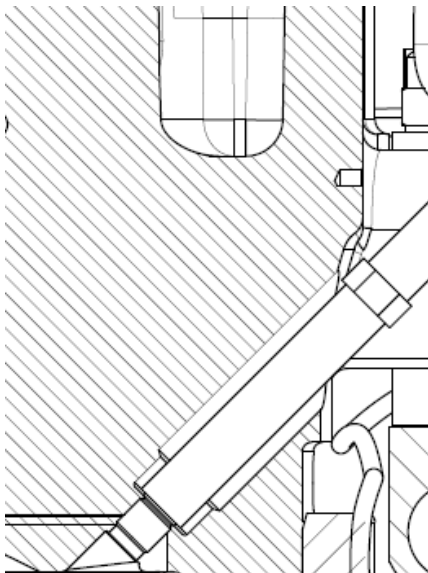

Head mounted installation near to combustion chamber

Connector

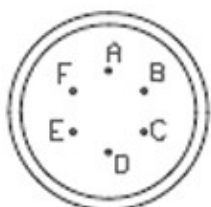

A = Power supply 18...32 V

B = Pressure signal output 4...20 mA

D = Signal zero point / Power GND

C = Programming pin, only used for calibration

E, F not connected

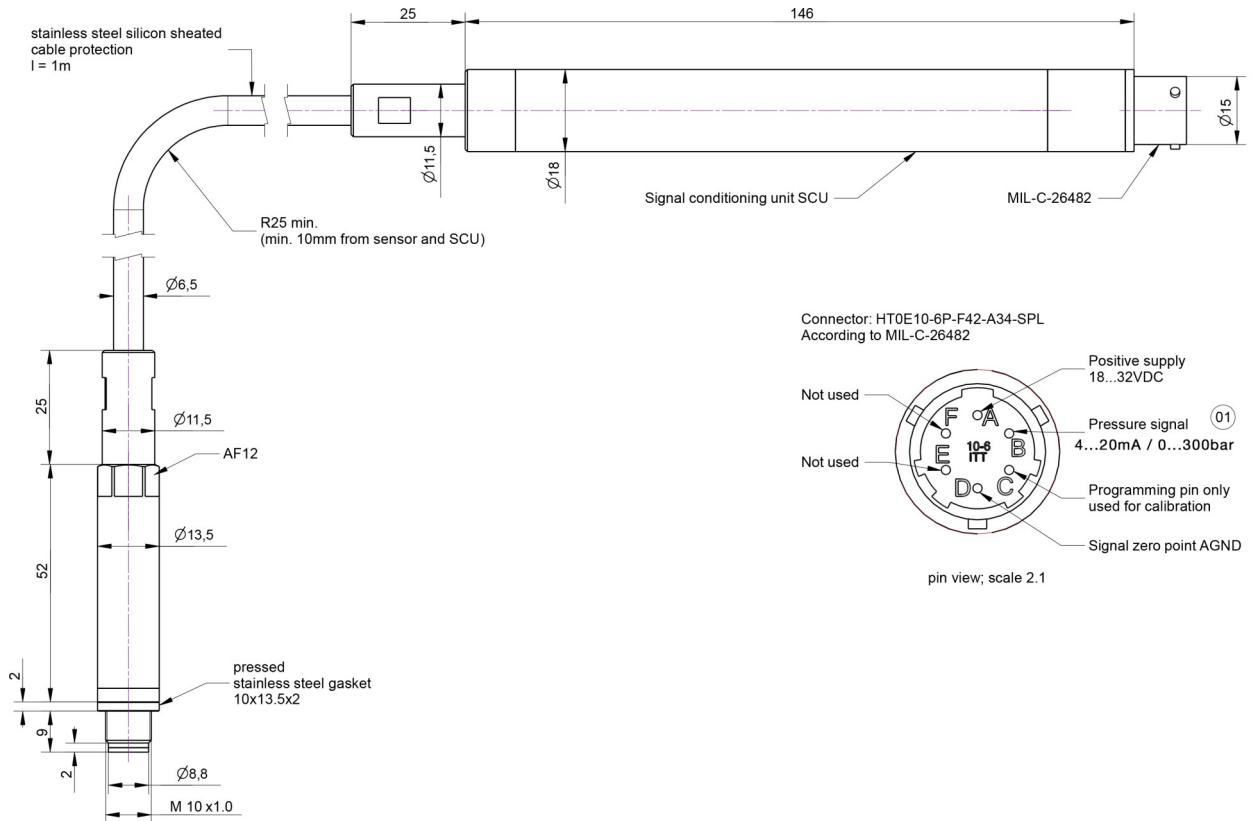

Product No.	Pressure range	Sensor length	Cable length	Static overpressure
IW-5850	0 - 300 bar	52 mm	1,0 m	1200 bar
IW-5851	0...300 bar	52 mm	1,0 m	800 bar
IW-5852	0...300 bar	52 mm	0,6 m	1200 bar

Optional Accessories

Protection cover

Sensor connecting cable incl. MIL-C-26482 connector 5 m

Sensor connecting cable incl. MIL-C-26482 connector 10 m

Product No.

IW-6211

IW-4132

IW-4133