

robust and durable

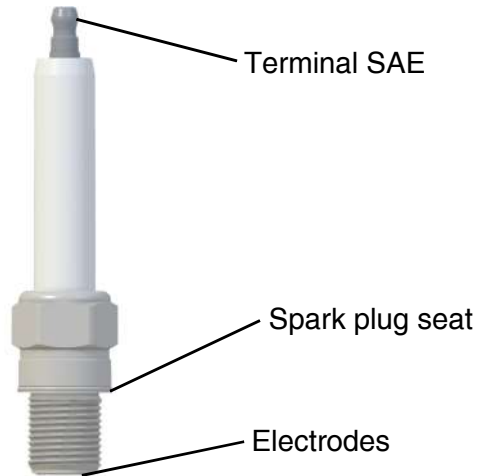

### General operation conditions

- Electrode temperature: max. 800°C
- Spark plug seat temperature: max. 200°C
- Terminal (SAE) temperature: max. 150°C
- High voltage robustness: < 55kV
- Spark voltage in operation: < 45kV

## Specialist for advanced engine control

### Our main products

- A wide range of cylinder pressure sensors for diesel-, gas-, dual-fuel- and future fuels engines
- Various types of handheld electronic engine analysers
- Combustion monitoring systems
- Industrial spark plugs

### Our service

- Advice and training for optimal use of our products
- Customised solutions for your requirements
- Service and support for our products

### Your benefit with IMES as your partner

- High quality products and services that meet the highest standards
- Expert support from our experienced team
- Tailored solutions that meet your specific requirements

### Global sales organisation



You are welcome to contact us at any time for further information and support.

Email: [sales@imes.de](mailto:sales@imes.de)  
Phone: +49 8341 9661730

**imes**  
the cylinder pressure people



## ISP-01 industrial spark plug



high performance  
long lifetime

[www.imes.de](http://www.imes.de)

# Industrial spark plug

IMES cylinder pressure sensors for internal combustion engines are well known to diesel- and gas engine manufacturers as they convince with their robustness, high accuracy and longevity. The goal is a reliable and efficiently running engine.

Due to our more than 25 years experience with cylinder pressure sensors and data acquisition systems we realized that a proper working spark plug is also an important component of a smooth-running engine. So, we decided to develop and to produce our own industrial spark plug type ISP-01.

## Application:

- Industrial stationary engines
- Prechamber combustion engines
- CHP generation
- Natural gas operation
- Biogas operation
- Landfill gas operation



## Main data:

- M18 x 1.5 mm thread industrial spark plug design
- with HEX 22.2 mm wrench size and SAE HV terminal
- 6k Ohm EMC suppressor resistance
- ring gap electrode design, no re-gapping needed
- High performance Ir/Rh composition material for both electrodes
- Semi-Shielded 4 bore spark plug design for high temperature applications
- Useable for different gas types (natural- or biogas application)
- Expected lifetime: min. 4,000 operating hours (depending on engine operation conditions)

## Field test:



Currently the ISP-01 spark plugs are successfully tested on a Jenbacher engine type 6

## Product details:

- Advanced design with optimised heat dissipation for low wear of electrodes

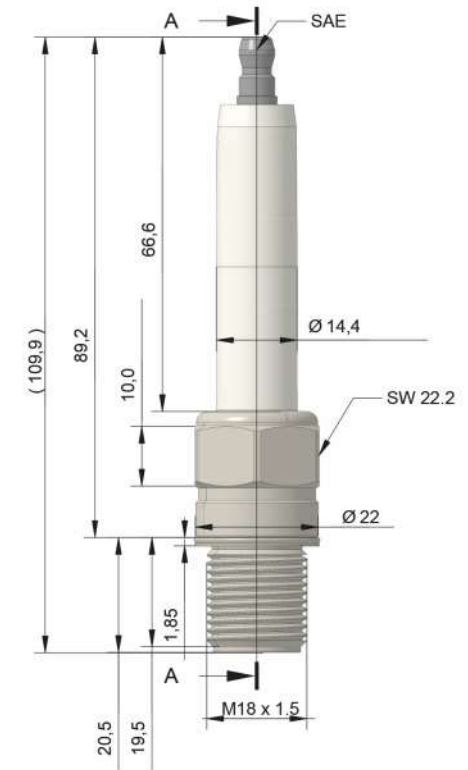

## Mechanical dimensions:

- SP thread: M18 x 1.5 mm
- Wrench size: 22.2 mm
- Diam. insulator: 14.4 mm
- Total length: 109.9 mm
- SAE top to seat: 89.2 mm
- Thread length: 19.5 mm
- SP reach: 20.5 mm
- Initial gap size: 0.3 mm (+/- 0.05 mm)